

13"

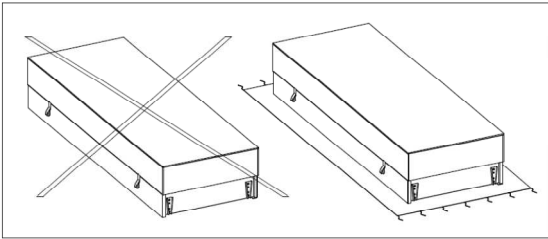

30min



Z

Z	1x
M	1x
L	1x
R	1x

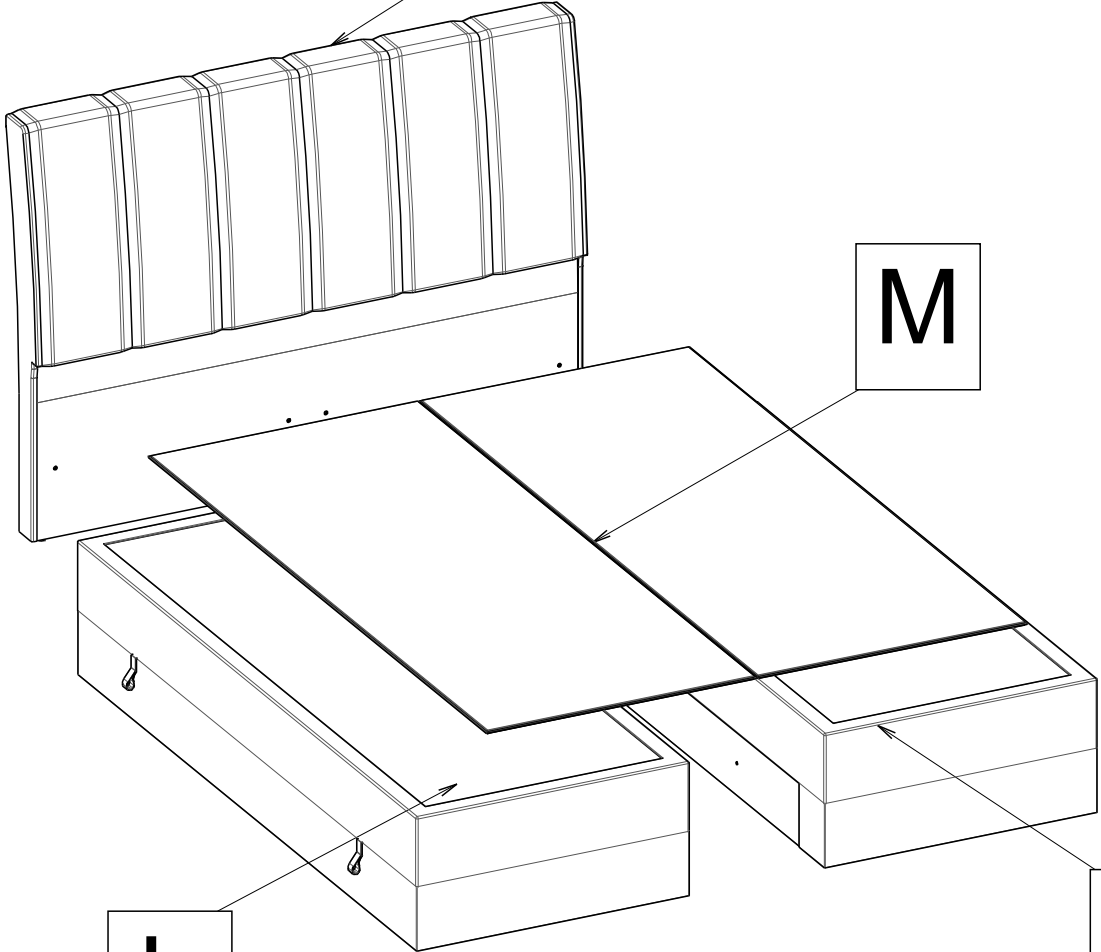

L

M

R

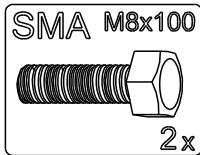
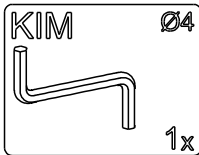
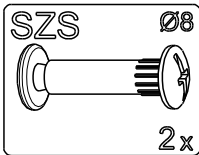
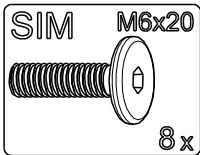
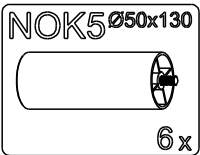
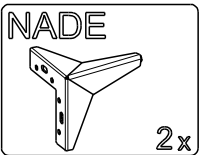
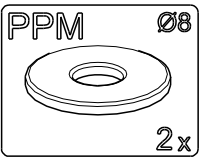

1

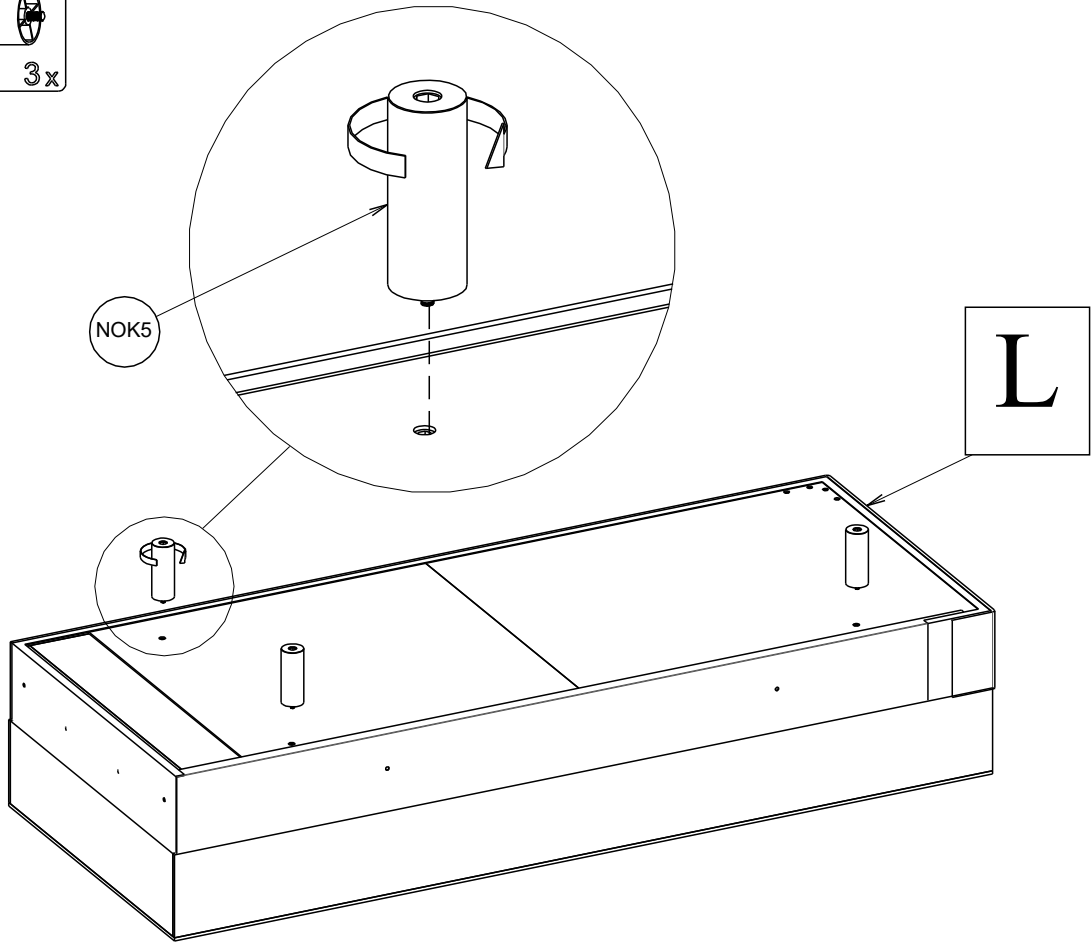
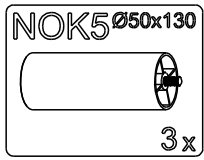

2

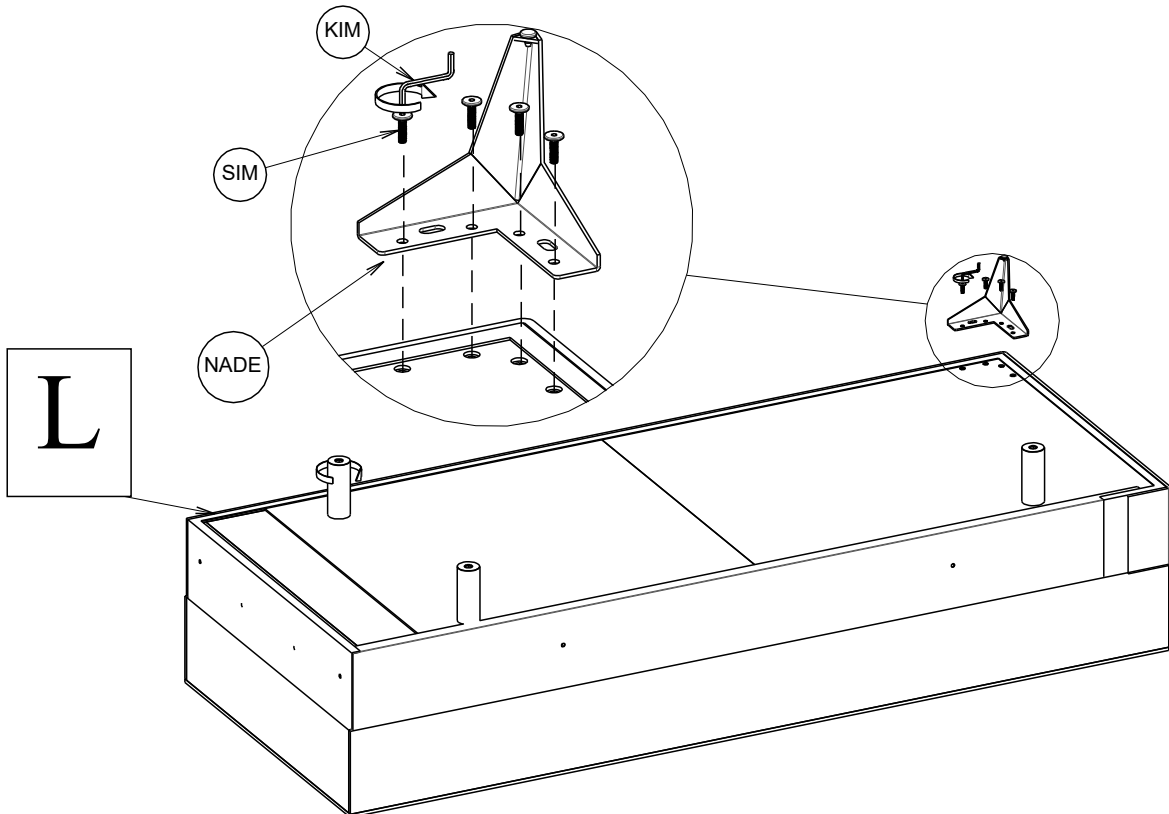
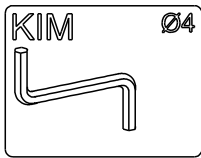
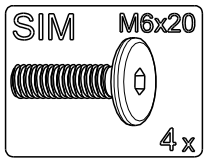
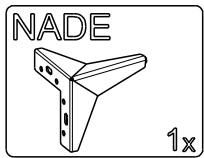

3

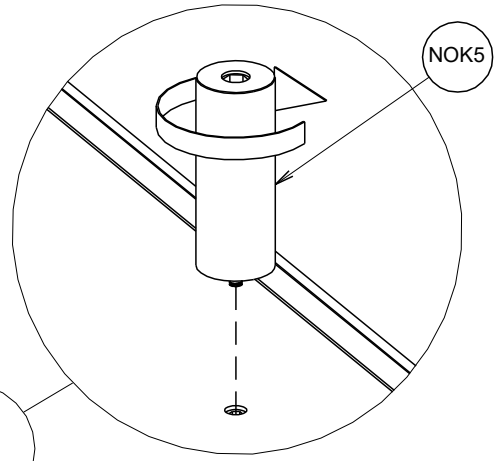
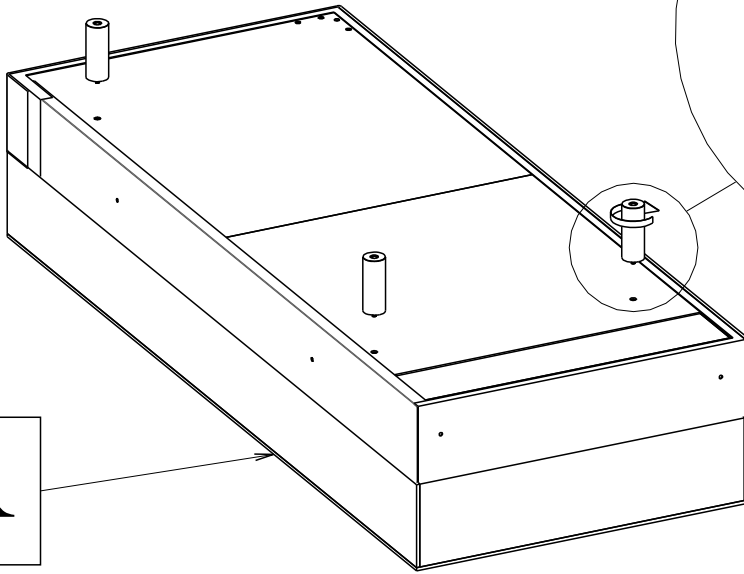
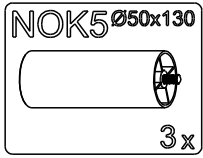

R

4

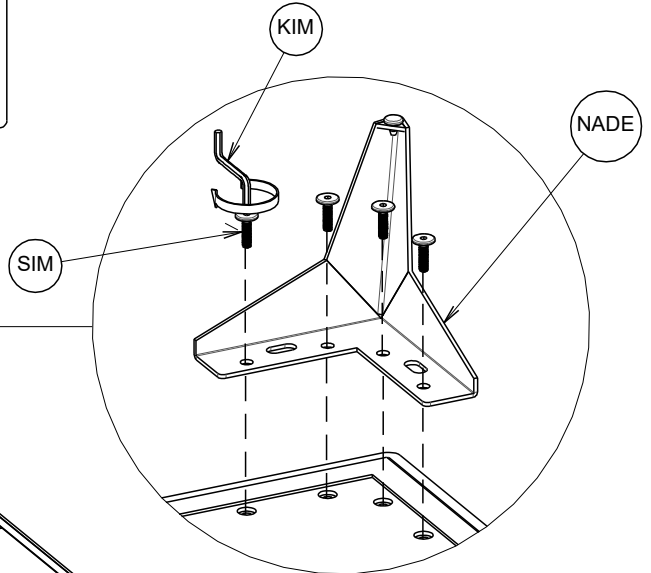
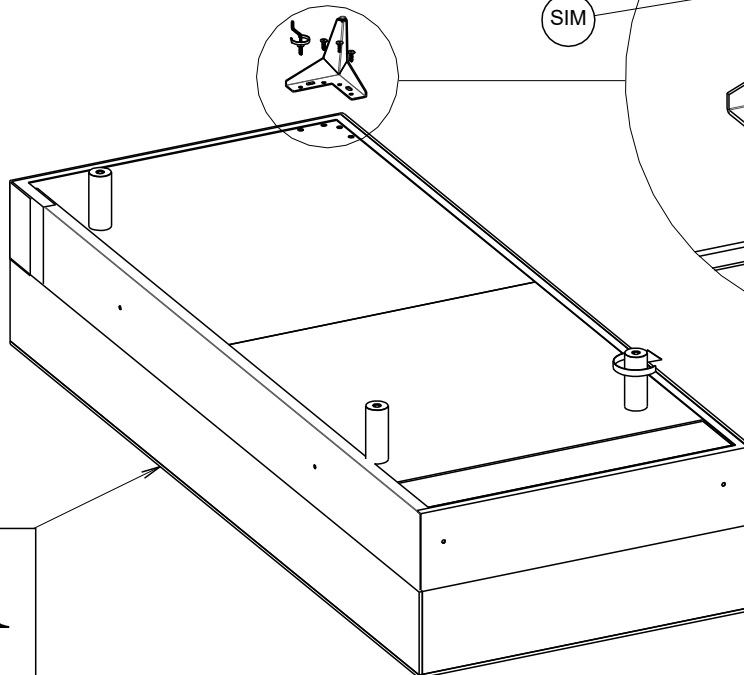
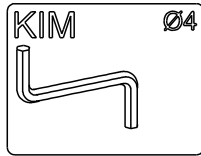
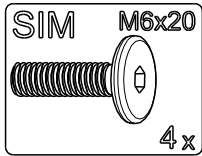
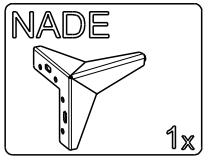

R

5

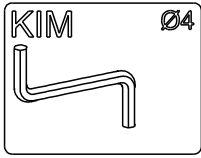
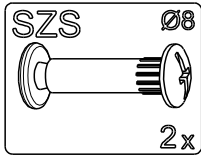

R

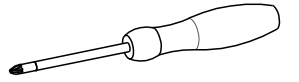

L

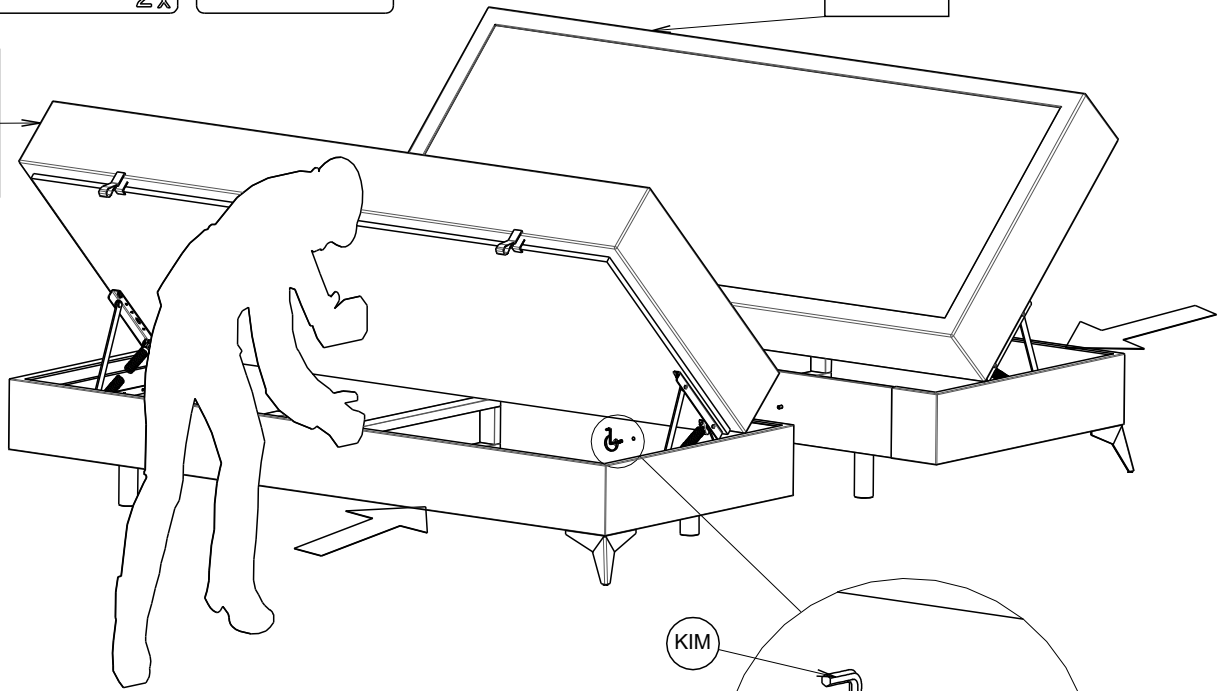

KIM

SZS

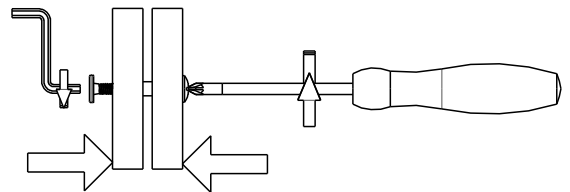
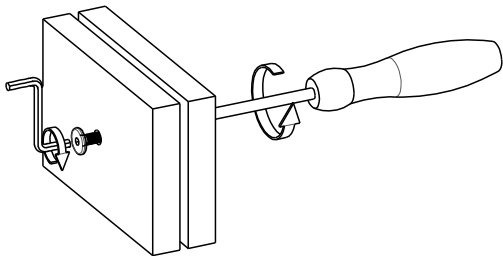

R

L

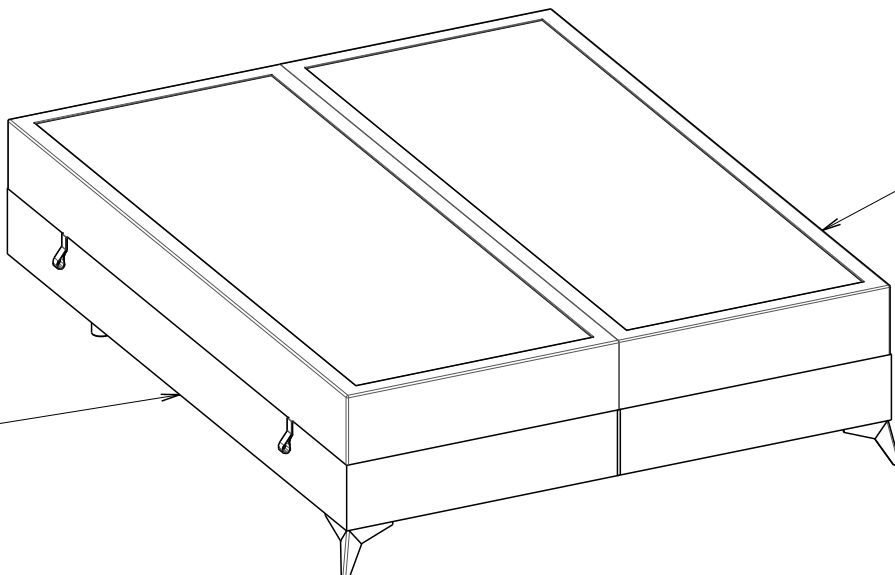

6

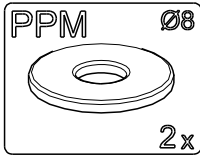
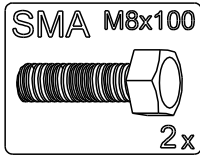

13"

Z

R

L

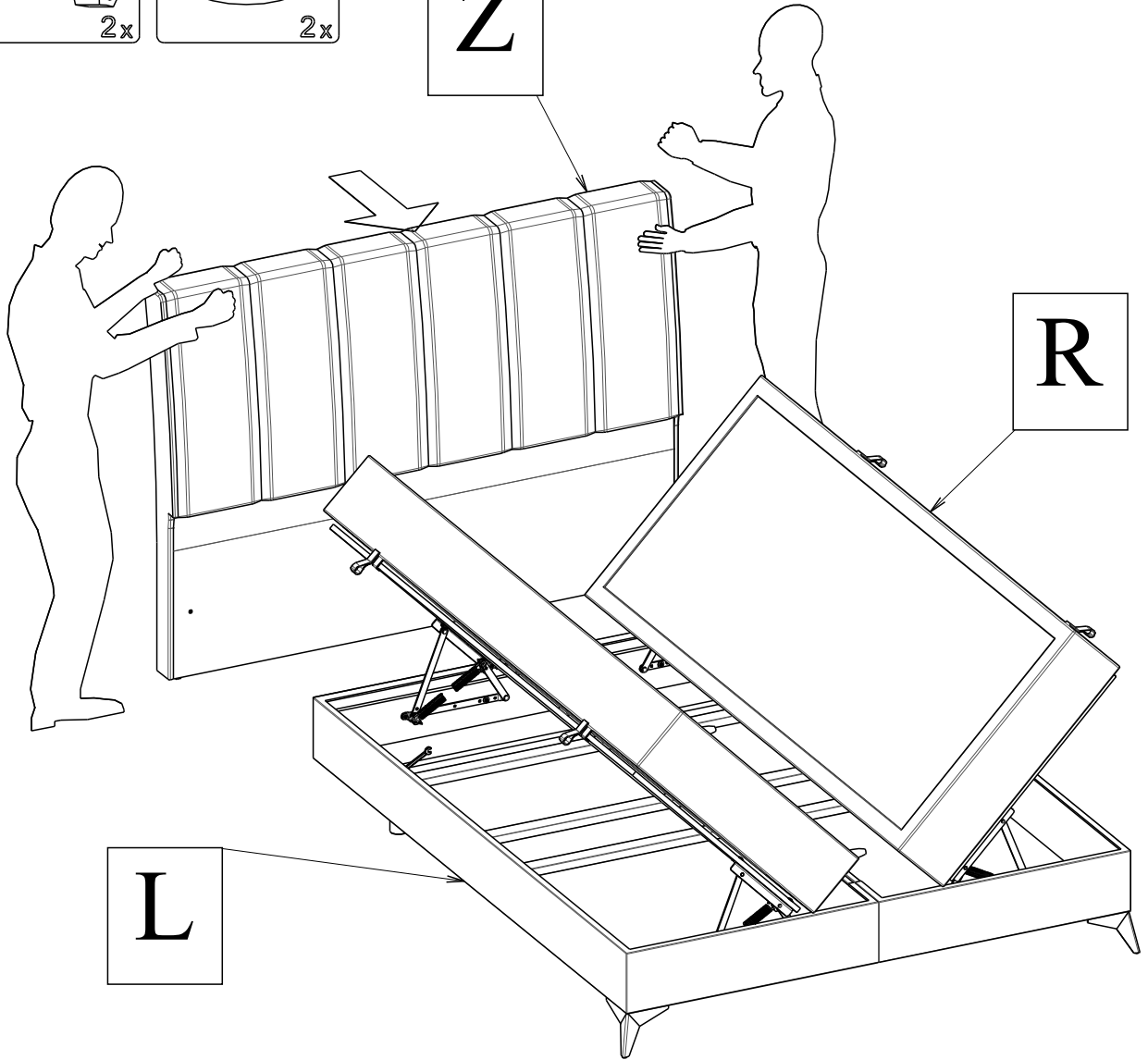

2x

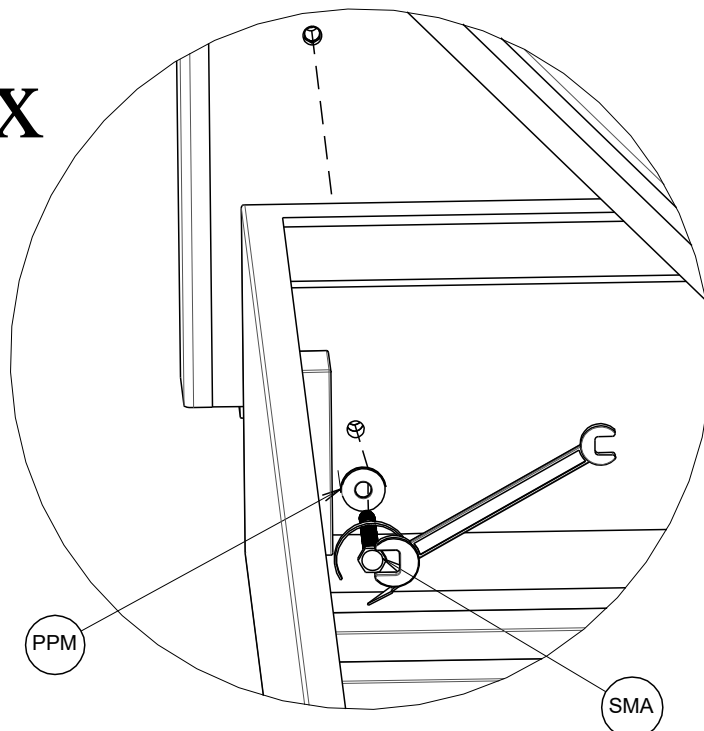

7

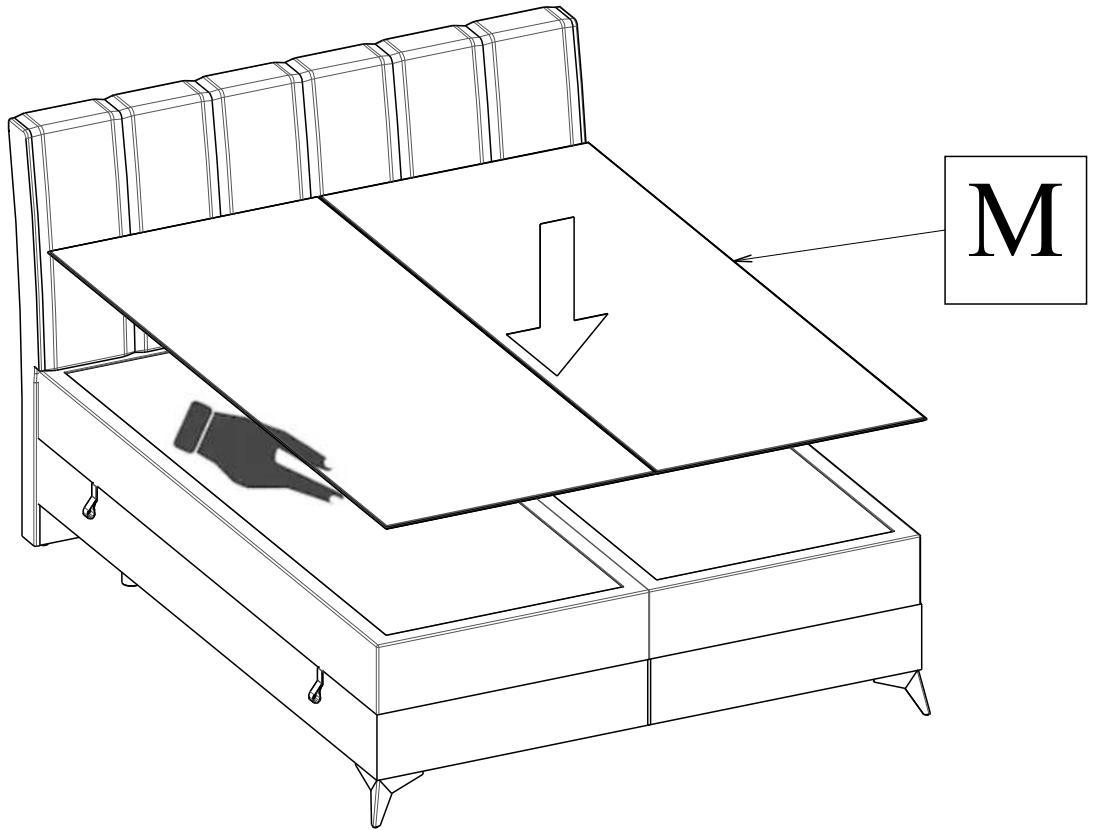

8

